

**NATIONAL
ACOUSTIC LABORATORIES
COMMONWEALTH DEPARTMENT OF HEALTH**



**INTERNAL REPORT NO. 16
INDUCTION FIELD WIRELESS HEARING AID**

**TECHNICAL SPECIFICATION FM-2b
NOVEMBER 1979**

**GRAHAM C. DONALD
ERIC R. BURWOOD**

SYDNEY, AUSTRALIA

NATIONAL ACOUSTIC
LABORATORY LIBRARY
No. AV — 21/2/71

Copy A

TECHNICAL SPECIFICATION FOR INDUCTION FIELD

WIRELESS HEARING AID - FM2b

C O N T E N T S

<u>Section</u>		<u>Page</u>
1.	SYSTEM DESCRIPTION	1 to 3
2.	TRANSMITTER SPECIFICATIONS	3 to 18
2.1	Induction Field Related Specification	3
2.1.1	Channel and Frequency Allocation	3
2.1.2	Modulation Type and Index	4
2.1.3	Frequency Stability	4
2.1.4	Final Stage Power	4
2.1.5	Field Strength	4
2.1.6	Spurious Field Strength	4
2.1.7	Ferrite Rod Antenna	5
2.2	Audio Circuit Specification	5
2.2.1	Audio Response, Microphone Inputs	5
2.2.2	Noise and Distortion	5
2.2.3	Microphone Requirements	5
2.2.4	Microphone Uses	6
2.2.5	AVC (Automatic Volume Control)	7
2.2.6	Speech Detector - Voice Operated Transmission (VOX)	7
2.2.7	External Input	8
2.3	Transmitter Control and Operation	9
2.3.1	Inhibit Control	9
2.3.2	P.T.T. - Press-to-talk Button	10
2.3.3	Modes of Operation	10
	Table I	11
2.3.4	P.T.T. Priority System	12
2.3.5	External Input	12
2.4	Battery and Associated Specifications	13
2.4.1	Battery Consumption, Capacity and Voltage	13
2.4.2	Battery Indicator	13
2.4.3	Battery Holder	13
2.4.4	Battery Contacts	14
2.5	External Controls, Labels, Contacts	14
2.5.1	Controls and Labels	14
2.5.2	Contacts, Sockets and Labels	16
2.5.3	Identification	16

CONTENTS (CONTD)

<u>Section</u>	<u>Page</u>
2.6 Physical Specifications	17
2.6.1 Size	17
2.6.2 Weight	17
2.6.3 Body Attachment	17
2.6.4 Drop Test	17
2.6.5 Additional Requirements	18
3. RECEIVER SPECIFICATION	18 to 27
3.1 Induction Field Related Specifications	18
3.1.1 Channel and Frequency Allocation - Modulation Type and Index	18
3.1.2 Sensitivity and Range Control Circuit	18
3.1.3 Noise Figure	18
3.1.4 Temperature Coefficient of Resonant Frequency	18
3.1.5 Ferrite Rod Antenna	19
3.1.6 De-emphasis	19
3.1.7 Circuit Type	19
3.1.8 Intermediate Frequency	20
3.1.9 Noise Activated Squelch	20
3.2 Audio and Control System Specification	20
3.2.1 Audio Output Stage	20
3.2.2 Inhibit and Mute Signals	21
3.3 Battery and Associated Specifications	22
3.3.1 Battery Consumption, Capacity and Voltage	22
3.3.2 Battery Indicator	22
3.3.3 Battery Holder	23
3.3.4 Battery Contacts	23
3.4 External Controls, Labels, Contacts and Sockets	24
3.4.1 Controls and Labels	24
3.4.2 Contacts, Sockets and Labels	25
3.4.3 Identification	26
3.5 Physical Specifications	26
3.5.1 Size	26
3.5.2 Weight	26
3.5.3 Body Attachment	26
3.5.4 Drop Test	27
3.5.5 Additional Requirements	27
4. SYSTEM OPERATION	27

CONTENTS (CONTD)

<u>Section</u>	<u>Page</u>
5. BATTERY CHARGER SPECIFICATION	27 to 28
5.1 Battery Charger Unit	27
5.2 Charging Rate	27
5.2.1 Normal Charging Rate	27
5.2.2 Boost Charging	28
5.3 Overcharge Battery Protection	28
5.3.1 Normal Charging Rate Protection	28
5.3.2 Boost Charging Rate Protection	28
5.4 Contacts	28
5.5 Multiple Charging Unit	28
6. ACCESSORIES	29
6.1 Cords	29
6.1.1 Y-Cord A	29
6.1.2 Y-Cord B	29
6.1.3 Single Cord A	29
6.1.4 Single Cord B	29
6.2 Additional Battery Packs and Holders	29
7. ADDITIONAL REQUIREMENTS	29 to 31
7.1 Case Parts	29
7.2 Case Colours	29
7.3 Controls	30
7.4 Temperature	30
7.5 Maintenance	30
7.6 Identification	30
7.7 Technology	30
7.8 Environmental Testing	30
Figure 1 - Block Schematic Transmitter	32
Figure 2 - Block Schematic Receiver	33
Figure 3 - Transmitter Pre-emphasis	34

1. SYSTEM DESCRIPTION

The wireless hearing aid system comprises a wearable transmitter and receiver, a battery charger unit and accessories. It will be used primarily for the education of deaf children, but it also has potential for an improved form of communication with deaf people generally. The wireless function is an option to support and encourage conventional hearing aid use and it is not intended that all communications be by "wireless".

1.2 The system employs the induction field as a new application for mobile-to-mobile communication. The prime advantage of this means of communication is service selection by proximity as opposed to service selection by frequency as used in RF systems. This service selection technique is made possible because the induction field falls off very rapidly, approximately as the inverse cube of the distance.

1.3 To overcome any difficulty in proximity service selection which may arise in special schools for the deaf, four frequency channels will be used because of the proximity of other transmissions in adjacent classrooms.

1.4 Features of the system are voice operated transmission (VOX), a press-to-talk switch and an automatic volume control (AVC) in the transmitter, and squelch operation in the receiver (2 modes). Also the transmitter may operate at two power levels.

Simplified functional block diagrams of the transmitter and receiver are attached (figs. 1 and 2). The transmitter and receiver may be electrically and physically coupled together, and used as a transceiver.

The transmitter diagram shows a "Transmitter Logic I.C." which is used to decode switch and control functions, and a "Transmitter Audio Processing I.C." (TX Audio I.C.) which processes inputs from the speech microphone, the control microphone and the external input.

1. SYSTEM DESCRIPTION (CONTD)

1.4 (Contd)

The proper audio signal is selected by a "Signal Selector Switch", inside the TX Audio I.C., controlled by the Logic I.C. Output from the selector switch is fed to the "Channel Generator", where frequency modulation takes place, and then to the "Transmitter Amplifier".

The channel generator will generate the normal transmitting frequency(ies) or an unmodulated carrier shifted 12.5 kHz. This shifted carrier will cause a DC shift on the Receiver audio output line and will be passed on to the users normal hearing aid where it will be detected and used to select either the wireless mode (local aid switched off by DC level) or normal local aid microphone mode (DC level shifted towards 0). Mixed wireless and local aid operation is also possible by blocking the DC voltage fed to the hearing aid by a capacitor.

The simplified functional block diagram of the receiver shows a single frequency change super-heterodyne circuit.

The IF signal is fed through a ceramic filter to the "Receiver I.C. Chip" where the functions of IF amplification limiting and demodulation takes place.

A range control circuit and a noise operated squelch are also included in the I.C. chip. Whenever a received signal is below the level required by the "Range Control" setting, or the squelch is operated, the audio output will be muted. An inhibit signal to a coupled transmitter is generated unless the audio is muted.

Another feature of the system is that the patient receives the final acoustic signal through his usual hearing aid which may be selected to give him maximum benefit for his particular hearing loss. This feature allows replacement or interchangeability of transmitters and receivers, implying that only the hearing aid, which is not part of this contract, has to be matched to the hearing loss of the individual. The specially adapted hearing aid will be either of the body-worn or behind-the-ear type. The aid would include an electronic switch and volume control for wireless reception and would be fitted with an input socket.

1. SYSTEM DESCRIPTION (CONTD)

- 1.5 The lightweight transmitter can be hand held or hung around the neck similar to a Lavalier microphone.
- 1.6 Further background for the system may be obtained from the following papers:
- (i) "A New System for Wireless Linked Auditory Trainers and Hearing Aids"
by V. Burgess, Australian Teacher of the Deaf,
July 1975, pp 26-30.
 - (ii) "Wireless Hearing Aids"
by V. Burgess.
To be published in Australian Journal of Human Communication Disorders.
 - (iii) "The Induction Field Wireless Hearing Aid"
by V. Burgess.
A talk given on 22 October 1976 to Burwood State College, Victoria.
 - (iv) "Induction Field Telephony"
by V. Burgess, NML Internal Report (in draft form).

2. TRANSMITTER SPECIFICATIONS

2.1 Induction Field Related Specification

2.1.1 Channel and Frequency Assignments

The transmitting frequency shall be switch selectable to one of four contiguous channels spaced at 50 kHz. The frequencies assigned are:

3125 kHz, 3175 kHz, 3225 kHz and 3275 kHz.

Frequencies around 3 to 4 MHz are necessary to obtain an induction field extending over a range of 12 metres.

2. TRANSMITTER SPECIFICATIONS (CONTD)

2.1.2 Modulation Type and Index

- (a) The transmission is to be of frequency or angle modulation type.
- (b) The maximum frequency deviation is to be 12.5 kHz rolled off at high audio modulation frequencies to give 30 kHz bandwidth occupancy.

2.1.3 Frequency Stability

All transmitters must be crystal controlled to within 20 Hz of the nominal carrier frequency over a temperature range of 0 to 45°C so that any beat frequencies generated between transmitters are inaudible. Outside this temperature range the transmitter should operate with reduced specifications between -10 and 0°C, and between 45 and 60°C.

2.1.4 Final Stage Power

DC input to the final stage of the transmitter shall be switch selectable between 60 milliwatt and 6 milliwatt. This specification is to apply for a battery supply voltage of 6.0 Volts.

2.1.5 Field Strength

The equivalent field strength is specified by an $(E \cdot R)^3$ product of 0.38 Volts (RMS) $(\text{metre})^2$ at a transmission range of 2 metres at an (experimental) frequency of 3.6 MHz, where E is field strength and R is distance. At other frequencies field strength will decrease as square root of frequency.

2.1.6 Spurious Field Strength

Spurious radiated field strength from the transmitter should be 60 dB below the level of that due to the radiated wanted signal.

2. TRANSMITTER SPECIFICATIONS (CONTD)

2.1.7 Ferrite Rod Antenna

- (i) The transmitting ferrite rod shall be no greater than 10 millimetres nominal diameter by 150 millimetres long.
- (ii) The ferrite rod must be mounted vertically (parallel to the length) inside the transmitter case.
- (iii) The ferrite rod must be no closer than 2.5 mm to the outside of the case.
- (iv) The ferrite rod must be suitably vibration and shock isolated to prevent it from being damaged.

2.2 Audio Circuit Specification

2.2.1 Audio Response

The frequency response of the transmitter should be:

- + 6 dB/oct, 100 Hz to 4 kHz
- + 12 dB/oct, below 100 Hz
- 6 dB/oct, above 6 kHz

This is the total response of the transmitting system, including the microphone response. (See 2.2.3 (iii)).

2.2.2 Noise and Distortion

The signal to noise ratio must be at least 34 dB for an input level of $200\ \mu\text{V}$ at 1 kHz. (S.P.L. = 60 dB), when measured in the bandwidth specified above. Also the signal to noise ratio must be at least 40 dB for an input level of 1 mV at 1 kHz. (S.P.L. = 74 dB).

2.2.3 Microphone Requirements

There will be two electret microphones in the transmitter unit. Both microphones must be vibration isolated and provided with a suitable wind shield.

2. TRANSMITTER SPECIFICATIONS (CONTD)

2.2.3 Microphone Requirements (Contd)

- (i) One microphone, the boom, or voice microphone, must be mounted at the end of a semi-flexible lightweight swivel mounted boom, 150 mm long by 5 mm diameter. The boom microphone will either be used with the boom in a locked position along the case front, (hand held), or in an upright position (body worn transmitter).
- (ii) The second microphone must be mounted near the swivel end of the boom. This microphone is called the control microphone.
- (iii) The microphones should have the following typical response:
 - + 6 dB/oct., 0 - 100 Hz
 - flat , 100 Hz to 2 kHz
 - + 6 dB/oct., 2 kHz to 4 kHz (+3 to 4 dB/oct. may be preferable)
 - at least -6 dB/oct. above 6 kHz.

The microphones should provide an E.M.F. of 200 μ V for an S.P.L. of 60 dB at 1 kHz, with a source impedance less than 6 Kohm.

2.2.4 Microphone Uses

- (i) The main purpose for the boom microphone specified in 2.2.3(i) will be to pick up voice sounds near the lips, leaving hands free. It will be used in situations where the best possible signal to noise ratio is of utmost importance, e.g., the teacher's unit in a classroom situation.
- (ii) The control microphone must control the maximum gain of the AVC (automatic volume control) stage when speech is not present. This control must operate over a range of ambient input levels from 60 to 120 dB S.P.L. and with a response similar to that of the boom or voice microphone.

2. TRANSMITTER SPECIFICATIONS (CONTD)

2.2.4 Microphone Uses (Contd)

- (iii) The control microphone must also be used in conjunction with the voice microphone specified to provide a noise cancelling effect of the low frequency components in the horizontal plane.
- (iv) The frequency response of the control microphone in the noise cancelling channel must be restricted to low frequencies. The signal through this channel must roll off at a nominal rate of 6 dB per octave above a corner point selected between 1 and 2 kHz. This must be a minimum phase network.

2.2.5 AVC (Automatic Volume Control)

- (i) The attack time of the AVC must be less than 5 millisecc and the release time must be controlled by an internally adjustable preset decay rate over a range from 10 to 40 decibels per second.
- (ii) The maximum gain of the AVC circuit should depend upon ambient sound conditions which will be sensed by the control microphone as described in 2.2.4(ii). This provision will reduce the amount that the gain of the amplifier would normally increase with no speech input. The amount of improvement will be equal to the difference in speech SPL between the voice and control microphones of the transmitter. The control microphone sensitivity should be higher by an amount equal to this difference, within the AGC range of the two sound channels.
- (iii) In addition, it must be possible to disable the AVC circuit for input levels below an internally adjustable preset threshold level which may range from 800 μ V to 8 mV, (72 to 92 dB S.P.L.), at 1 kHz. (See Figure 3)

2.2.6 Speech Detector - Voice Operated Transmission (VOX)

- (i) A speech detector circuit must be incorporated in the transmitter.
- (ii) It must discriminate speech from ambient background noise in the range 50 to 100 dBA. (Noise source to give specified reading on a dBA calibrated meter).

2. TRANSMITTER SPECIFICATIONS (CONTD)

2.2.6 Speech Detector - Voice Operated Transmission (Contd)

- (iii) Advantage may be taken of the fact that a person normally raises his voice in noisy conditions and the microphone will be used close to the lips under these conditions.
- (iv) The speech detector circuitry will need special considerations so that it can accurately detect a soft longish sound such as 'S' occurring at the beginning of transmission.
- (v) It must have provision for an internally preset control which will accommodate a pre-selectable hang time from 0.5 to 3.0 seconds.
- (vi) The output of the speech detector circuit must be a two state control signal feeding the Logic circuit and activating the VOX mode of operation.

2.2.7 External Input

- (i) Provision must be made for an external electrical input signal.
- (ii) The external input must have its own AVC circuit.
- (iii) The attack time of the AVC must be less than 5 milliseconds and the release time must be controlled by an internally adjustable preset decay rate over a range from 10 to 40 decibels per second. A slower decay rate (< 10 dB/sec.) is desirable, and should be aimed at.
- (iv) The AVC circuit must operate with inputs between 10 millivolt (RMS) and 1.0 Volt (RMS) and must be capable of handling a crest factor of 5 (i.e., 5 Volt peak maximum input).
- (v) Input impedance of the external input must be 100 kilohms.

2. TRANSMITTER SPECIFICATIONS (CONTD)

2.2.7 External Input (Contd)

- (vi) The frequency response of the external input circuitry must roll off at a nominal rate of 12 dB/octave below a corner point at 100 Hz. Above this frequency the response should rise at 6 dB/octave to at least 4 kHz.
- (vii) The external input must be protected against damage from large input signals ranging from plus to minus 50 Volts peak.
- (viii) See 2.3.5 for control and operation.

2.3 Transmitter Control and Operation

- (i) An independent transmitter is defined as a transmitter not coupled to a receiver.
- (ii) A "coupled transmitter" or "coupled transmitter-receiver" is defined as a transmitter electrically coupled to a receiver such that the control signal generated in the receiver can be used to inhibit the transmitter except when the source transmitter is that coupled transmitter.
- (iii) A "coupled receiver" is defined as that receiver associated with a coupled transmitter.

2.3.1 Inhibit Control

- (i) It must be possible for the transmitter to accept an inhibit control signal from a receiver coupled to it.
- (ii) The Logic levels of this signal, must be:
 - (a) < 0.9 volts when transmitter inhibition is required, and
 - (b) $> (V_{CC} - 0.9 \text{ volts})$ when inhibition of the transmitter is not required.
- (iii) When transmitter inhibition is required as determined by a coupled receiver (see later), then it must not be possible for the coupled transmitter to commence transmission.

2. TRANSMITTER SPECIFICATIONS (CONTD)

2.3.1 Inhibit Control (Contd)

- (iv) Once a transmission has commenced, then it must not be possible for a coupled transmitter to be inhibited by the inhibit control signal from the receiver.

2.3.2 P.T.T. - Press-to-talk Button

- (i) A press-to-talk push button must be included on the transmitter.
- (ii) The PTT will allow manual initiation of a transmission in either the "VOX" or "H.A.MIC." mode of operation.
- (iii) The duration of the transmission using the PTT button in the "H.A.MIC." mode would be determined by the length of time that the PTT button was pressed.
- (iv) In the "VOX" mode transmission must begin at the commencement of speech or if the PTT button is pressed. Transmission must continue until the end of one hang time period after both speech has ceased and PTT is released.
- (v) The above (iv) does not apply when TX-RX are coupled and the transmitter is in 1-WAY/VOX mode.

In this mode, provided the transmitter is not inhibited, a transmission must only commence if PTT is pressed. Speech transmission may then start while PTT is pressed or within 3 seconds after PTT is released. Transmission then should continue for as long as the VOX circuit is activated by speech. The normal speech hang time applies provided PTT is released before speech ceases.

2.3.3 Modes of Operation

The required combinations of settings of the H.A. Control switch (TX.MIC-VOX-H.A.MIC.) with the Transmitter Control switch for both coupled and independent transmitters is explained by Table I.

	INDEPENDENT UNITS		COUPLED UNITS	
	1. WAY	2. WAY	1. WAY	2. WAY
TX MIC.	Normal modulated carrier transmitted	Normal modulated carrier transmitted	Normal transmission when TX is not inhibited	Normal transmission when TX is not inhibited
(no hangtime)	Normal transmission when speech (or P.T.T.)	Normal transmission when speech (or P.T.T.)	Transmission may only be started by momentarily operating P.T.T. while TX is not inhibited.	Normal transmission when speech (or P.T.T.) if TX is not inhibited.
VOX	<u>Shifted carrier</u> transmitted when no speech (or not P.T.T.)		3 seconds to start speaking after release of P.T.T.	
for hangtime see para. 2.3.2.				
H.A.MIC.	Shifted carrier transmitted. (Normal transmission when P.T.T.)	P.T.T. gives normal transmission.	P.T.T. gives normal transmission if TX is not inhibited	
(no hangtime)				

TABLE I

2. TRANSMITTER SPECIFICATIONS (CONTD)

2.3.4 P.T.T. Priority System

- (i) Provision must be made for a priority switch inside the transmitter. With the switch closed the PTT function would have priority 1 (normally teacher), with the switch open the priority would be 2 (normally pupil). The switch should be accessible through a small hole in the case wall.
- (ii) If a transmitter receives an inhibit signal from its coupled receiver then :
 - (a) A pressed PTT button in a Priority 1 transmitter would cause transmission to begin as soon as the inhibit signal ceases.
 - (b) A pressed PTT button in a Priority 2 transmitter would not cause transmission to begin when the inhibit signal ceases.

The PTT button in a Priority 2 transmitter would only start the transmission if it was pressed while no inhibit signal was present.
- (iii) Features a) and b) above must also apply if "TX MIC." is selected instead of PTT.

2.3.5 External Input

- (i) A transmitter must accept modulation from a signal at the "external input" socket when in the transmit mode. The external input must be activated when a plug is inserted in the external input socket.
- (ii) If the PTT button is pressed the external input must be inhibited and the internal modulation channel activated. Switching "clicks" if perceptible during such operation are subject to N.A.L. approval.
- (iii) If a coupled Priority 1 transmitter receives an inhibition signal from its coupled receiver then transmission of the external program material will be transmitted the moment the inhibit ceases. With a Priority 2 transmitter this does not occur. (See 2.3.4 (ii) and (iii)).

2. TRANSMITTER SPECIFICATIONS (CONTD)

2.4 Battery and Associated Specifications

2.4.1 Battery Consumption, Capacity and Voltage

- (i) Total average transmitter power consumption at maximum power as specified in 2.1.4 must be less than 80 milliwatt.
- (ii) The transmitter must be capable of using a rechargeable battery or batteries which must give an operating time of at least 16 hours on one charge as specified in Section 5. This performance must also be met after 150 charge/discharge cycles of the battery.
- (iii) The transmitter must also be capable of operating on primary cells which can be readily installed in the transmitter. That is the primary cells must be physically the same size as the secondary cells specified in section (ii).
- (iv) The transmitter must operate over a battery voltage range from 4.2 to 6.8 volts and must meet relevant specifications over this range.

2.4.2 Battery Indicator

An L.E.D. must be provided, to indicate that the battery voltage is well above the minimum level for proper operation of the transmitter.

This L.E.D. must flash once every time PTT is released, provided the battery voltage is above a set reference level.

2.4.3 Battery Holder

- (i) Rechargeable Battery Holder.
 - (a) A rechargeable battery holder must be supplied.
 - (b) It must be possible for the contractor or NAL to seal the battery holder to prevent removal of batteries.

2. TRANSMITTER SPECIFICATIONS (CONTD)

2.4.3 Battery Holder (Contd)

(c) Also the battery holder must operate a mechanical interlock which will allow the battery charger to charge only the rechargeable cells.

(d) This battery holder may be of a disposable type.

(ii) Primary Battery Holder

(a) A separate reloadable battery holder for primary batteries must be supplied.

(b) It must operate a mechanical interlock which would inhibit charging of primary cells if a transmitter was accidentally plugged into the charger while operating on primary cells.

(NOTE: Primary cells may explode if recharging is attempted).

(c) Similarly, the separate primary battery holder must not allow charging of primary cells if the holder was accidentally plugged into the charger unit.

2.4.4 Battery Contacts

See Section 2.5.2 (iii).

2.5 External Controls, Labels, Contacts and Sockets

2.5.1 Controls and Labels

(i) Transmitter Control Switch - This switch must have three positions and must be easily accessible and operate silently. It must be labelled :

(a) Off

(b) 1. WAY

(c) 2. WAY

2. TRANSMITTER SPECIFICATIONS (CONTD)

2.5.1 Controls and Labels (Contd)

(ii) H.A. Control Switch - This must be a three position rocker switch which must be positioned for ease of one handed operation. Also it must operate silently. It must be labelled :

(a) TX. MIC/EXT.

(b) VOX

(c) H.A. MIC

(iii) Push-to-talk Switch - This must be an easily operated push button switch. It must operate silently and be positioned close to the "mode" switch. It must be labelled :

(a) P.T.T.

(iv) Channel Selector - This must be a four position switch, which must be relatively accessible and silent in operation. It must be labelled :

(a) "1" - for main channel

(b) "2"

(c) "3"

(d) "4"

Provision must be made for replacing the channel selector with a blank panel for single channel operation.

(v) Power switch - this must be a two position switch for High or Low power. It must be labelled :

(a) High

(b) Low

Provision must be made for replacing the power switch with a blank panel for single power operation.

(vi) Colour coding - commonly used switch combinations should be colour coded for ease of operation.

2. TRANSMITTER SPECIFICATIONS (CONTD)

2.5.2 Contacts, Sockets and Labels

- (i) Inhibition Control Contacts - Three miniature contacts must be provided to accept the transmitter inhibition signal and "Linked" signal from the receiver when this facility is required. This mode of operation must be automatically selected when the receiver is clipped to the transmitter by a dove-tailed joint or other method approved by NAL. The transmitter must have the male portion of the dove-tail on the front surface of the transmitter.

- (ii) External Input - A small jack must be provided for external input. It should be labelled :
 - (a) Ext.

- (iii) Battery Contacts or Sockets
 - (a) Battery contacts or sockets must be supplied for recharging secondary cells.

 - (b) The contacts must be constructed from a corrosion resistant material such as stainless steel (Copper based alloys are highly susceptible to corrosion problems and are not preferred).

 - (c) The contacts or sockets should be such that the transmitter orientation in the charger does not affect the charging polarity if applicable.

2.5.3 Identification

- (i) Each transmitter must have a clearly marked identification number or serial number.

- (ii) Manufacturer's name or any advertising matter must not appear on the transmitter unless approved by NAL.

2. TRANSMITTER SPECIFICATIONS (CONTD)

2.5.3 Identification (Contd)

- (iii) A flat rectangular surface 15 x 40 mm must be provided on each transmitter. The user's name will be inserted in this area for identification purposes. The identification will be by means of engraving.
- (iv) The name of the system to be determined by NAL must appear on all transmitters whether produced for NAL or for private sale.
- (v) Each unit must bear wording approved by NAL indicating that the system was developed by NAL.

2.6 Physical Specifications

2.6.1 Size

Nominal transmitter size must be less than 155 millimetres long, 60 millimetres wide by 16 millimetres thick (excluding boom microphone and protrusions such as dove-tail etc.). The transmitter must have rounded corners and edges for comfortable hand held operation. It must also provide a good grip for the hand.

2.6.2 Weight

Transmitter weight must be less than 300 grams. Preference will be given to a lighter unit.

2.6.3 Body Attachment

The transmitter when used on the body must be attached by straps around the neck and chest. The method of attachment must be by large press-stud type fasteners or other method approved by NAL.

2.6.4 Drop Test

- (i) The transmitter must not be damaged and must operate to specifications after being dropped onto a concrete floor from the height of one metre.

2. TRANSMITTER SPECIFICATIONS (CONTD)

2.6.4 Drop Test (Contd)

- (ii) The transmitter must only suffer minor surface damage when dropped onto a concrete floor from a height of two metres. It must still function satisfactorily after this test.

2.6.5 Additional Requirements

See Section 7.

3. RECEIVER SPECIFICATION

3.1 Induction Field Related Specifications

3.1.1 Channel and Frequency Allocation - Modulation Type and Index

same as for transmitter specifications 2.1.1 and 2.1.2.

3.1.2 Sensitivity and Range Control Circuit

The basic receiver sensitivity will be determined by the Q of the ferrite rod tuned circuit, the permeability and noise figure. However, the sensitivity must be variable to give an adjustable receiving range from 12 metres to 1 metre. This variable sensitivity will be provided by a range control graduated from 1 to 7. The graduations should as closely as practicable agree with the maximum distance in metres. Beyond 7 metres the control may be uncalibrated. The range control must be a user operated control. The output of the Range Control circuit must be a logic signal, indicating whether the receiver is inside or outside the range set on the control.

3.1.3 Noise Figure

The noise figure of all stages prior to limiting must be better than 2 dB.

3.1.4 Temperature Coefficient of Resonant Frequency

Temperature coefficient of the resonant frequency of the tuned ferrite rod must be less than 50 ppm per degree centigrade over a temperature range from 0°C to 45°C.

3. RECEIVER SPECIFICATION (CONTD)

3.1.5 Ferrite Rod Antenna

- (i) Temperature coefficient of inductance of ferrite rod must not exceed 500 ppm per degree centigrade over the temperature range specified in 3.1.4.
- (ii) The Q of the ferrite rod and tuning capacitor must exceed 200 at the operating frequency.
- (iii) The required dimensions of the receiving ferrite rod is approximately 10 millimetres nominal diameter by 58 millimetres in length.
- (iv) The ferrite rod must be mounted vertically.
- (v) The ferrite rod must be no closer than 2.5 mm to the outside of the case.
- (vi) The ferrite rod must be suitably vibration and shock isolated to prevent it from being damaged.
- (vii) The ferrite rod must be mounted internally.

3.1.6 De-emphasis

The receiver must not include any de-emphasis. This will be individually catered for in the hearing aid which will be optimally tailored to meet the requirements for the type of hearing loss to be fitted.

3.1.7 Circuit Type

The circuit type must be a single frequency change superheterodyne.

3. RECEIVER SPECIFICATION (CONTD)

3.1.8 Intermediate Frequency

The intermediate frequency must be 455 kilohertz.

The IF filter must have the following bandwidth characteristic:

-3 dB, BW must be 26 kHz

-6 dB, BW must be no greater than 35 kHz

-70 dB, BW must be no greater than 60 kHz

Breakthrough must not be more than 2 dB above the theoretical breakthrough. Any deviation from this must be approved by NAL.

3.1.9 Noise Activated Squelch

(i) A noise activated squelch must be included in the receiver. This circuit can be activated by noise above the speech band.

(ii) The sensitivity of the noise detector must be preset adjustable to between 10 and 20 dB S/N.

(iii) The output from the noise detector must be a logic signal.

(iv) Activation and release times for the squelch to be approved by N.A.L.

3.2 Audio and Control System Specification

3.2.1 Audio Output Stage

(i) The output of all receivers must be constant to within ± 1 dB for a constant FM deviation. This must also apply over the battery operating voltage range as specified in 3.3.1(iv).

(ii) Output impedance must be low enough and/or the signal level high enough such that a "V" cord (see accessories) from receiver to hearing aids, does not pick up RF hash (interference).

(iii) Also the output impedance and level must be able to drive 0.97 milliwatt of power into a high impedance(425 Ω) ear-phone. This will allow a teacher or parent to carry out a quick qualitative system check.

3.2.1 Audio Output Stage (Contd)

- (iv) The receiver output must be D.C. coupled and short circuit protected.
- (v) The audio output must have a "mute" switch, enabling the audio to be muted by the range control circuit or the squelch.
- (vi) When the received frequency is shifted 12.5 kHz above the nominal channel frequency the D.C. level of the audio output should be shifted towards ground by an amount corresponding to the peak audio output voltage.

Audio D.C. levels (no shift) are shown below:

°C	-10	25	65	
Min.	1.5	1.4	1.2	Volts
Nom.	1.7	1.51	1.3	Volts
Max.	1.8	1.6	1.5	Volts

The "shifted" voltage is always 1.06 volt \pm 1 dB lower than the normal D.C. voltage.

3.2.2 Inhibit and Mute Signals

The logic levels from the Range Control and the Noise Detector must be used to generate the following control signals :

(a) Audio Mute Signal

This must be a logic level used to operate the Audio Mute Switch whenever the Range Control circuit indicates that the receiver is outside the range set by the Range Control or noise is detected by the Noise Detector.

(b) Transmitter Inhibition Control Signal

This must be a logic level, used to inhibit a coupled transmitter whenever the audio stage is not muted.

(c) Hearing Aid Control Signal

- (i) The D.C. level at the audio output shall be used to control the ordinary hearing aid and must therefore be D.C. coupled to it.
- (ii) The normal (approximately 1/2 rail) voltage present at the audio output terminal shall be used to inhibit the local aid microphone when wireless reception is desired.
- (iii) Audible "clicks" associated with the use of the "shift" facility must be approved by N.A.L.

3. RECEIVER SPECIFICATION (CONTD)

3.2.2 Inhibit and Mute Signals (Contd)

- (iv) Mixed wireless and hearing aid microphone sound must be possible by interrupting the D.C. path, but letting the audio signal pass through a capacitor.

3.3 Battery and Associated Specifications

3.3.1 Battery Consumption, Capacity and Voltage

- (i) Total average receiver power consumption must be less than 17 milliwatt at a battery voltage of 1.2 volts.
- (ii) The receiver must be designed to use a rechargeable battery, or batteries, which must provide an operating time of at least 16 hours on one charge as specified in Section 5. This performance must also be met after 150 charge/discharge cycles of the battery.
- (iii) The receiver must also operate on primary cells which can be readily installed in the receiver. That is, the primary cells must be physically the same size as the secondary cells specified in section (ii).
- (iv) The receiver must operate over a battery voltage range from 1.0 to 1.6 volts and must meet relevant specifications over this range.
- (v) A DC-DC converter may be used to generate the supply voltage for the receiver. This supply voltage must be in the range 3.15 to 5.0 volts.

3.3.2 Battery Indicator

An L.E.D. must be provided, to indicate that the supply voltage is well above the minimum level for proper operation of the receiver, i.e. above 3.15 volts.

This L.E.D. must flash once every time a "Transmitter Inhibit Control" signal is generated (see 3.2.2 (b)), provided the supply voltage is above a set reference level.

3. RECEIVER SPECIFICATION (CONTD)

3.3.3 Battery Holder

(i) Rechargeable battery holder:

- (a) The rechargeable battery holder must be supplied by the contractor.
- (b) It must be possible for the contractor or NAL to seal the battery holder to prevent removal of batteries.
- (c) Also the battery holder must operate a mechanical interlock which will allow the battery charger to charge only the rechargeable cells.
- (d) This battery holder may be of a disposable type.

(ii) Primary Battery Holder

- (a) A separate reloadable battery holder for primary batteries must be supplied
- (b) It must operate a mechanical interlock which would inhibit charging of primary cells if a receiver was accidentally plugged into the charger while operating on primary cells.
(NOTE: Primary cells may explode if recharging is attempted).
- (c) Similarly, the separate primary battery holder must not allow charging of primary cells if the holder was accidentally plugged into the charger unit.

3.3.4 Battery Contacts

See Section 3.4.2 (iii).

3. RECEIVER SPECIFICATION (CONTD)

3.4 External Controls, Labels, Contacts and Sockets

3.4.1 Controls and Labels

- (i) Battery-wireless Switch - This switch must have three positions and must be easily accessible. It must be labelled :
 - (a) Off
 - (b) TX - which indicates transmitter controlled reception
 - (c) C - which indicates Combined Wireless and H.A. acoustic signals

- (ii) Channel Selector - This must be a four position switch, which must be relatively accessible. It must be labelled :
 - (a) "1" - for main channel
 - (b) "2"
 - (c) "3"
 - (d) "4"

Provision must be made for replacing the channel selector with a blank panel for a single channel operation.

- (iii) Range Control - This must be a potentiometer, which must be relatively accessible. The case must be labelled :
 - (a) "m" (for metres)
 - (b) The knob must be labelled at equal graduations 1 to 7, and M or MAX. if there is room for it.

- (iv) Control Protector - Provision is required for a control cover to be fitted over all controls to prevent young children from operating them.

3. RECEIVER SPECIFICATION (CONTD)

3.4.2 Contacts, Sockets, and Labels

(i) Transmitter Inhibit Control Contacts

(a) Three miniature contacts must be provided as an integral part of the female portion of a dove-tail on the back surface of the receiver. This dove-tail must be used to physically mount the receiver to the transmitter. No label will be necessary on these three contacts. Provision must be made for preventing the receiver and transmitter from separating in normal use.

(b) The contacts must be constructed from a corrosion resistant material such as stainless steel (copper based alloys are highly susceptible to corrosion problems and are not preferred).

(ii) Hearing Aid Output Socket - The output socket must be a miniature two conductor type approved by NAL. It must be labelled :

(a) Aid.

(iii) Battery Contacts or Sockets

(a) Battery contacts or sockets must be supplied for recharging secondary cells.

(b) The contacts must be constructed from a corrosion resistant material such as stainless steel (copper based alloys are highly susceptible to corrosion problems and are not preferred).

(c) The contacts or sockets should be such that the transmitter orientation in the charger does not affect the charging polarity if applicable.

3. RECEIVER SPECIFICATION (CONTD)

3.4.3 Identification

- (i) Each receiver must have a clearly marked identification number or serial number.
- (ii) Manufacturer's name or any advertising matter must not appear on the receiver unless approved by NAL.
- (iii) A flat rectangular surface 15 x 40 mm must be provided on each receiver. The user's name will be inserted in this area for identification purposes. The identification could be by means of an adhesive label, waterproof ink or engraving.
- (iv) The name of the system to be determined by NAL must appear on all receivers whether produced for NAL or for private sale.
- (v) Each unit must bear wording approved by NAL indicating that the system was developed by NAL.

3.5 Physical Specifications

3.5.1 Size

Nominal single channel receiver size must be less than 65 millimetres long, 53 millimetres wide by 16 millimetres thick. Nominal size for a 4-channel receiver must be less than 75 mm long, 53 mm wide by 16 mm thick. The receivers must have rounded corners and edges.

3.5.2 Weight

Receiver weight must be less than 90 grams. Preference will be given to a lighter unit.

3.5.3 Body Attachment

A pocket clip must be provided on the receiver for secure mounting to shirt pocket. In addition, a female portion of a dove-tail must be included in the case design so that the receiver can be securely mounted to the front surface of a transmitter when required.

3. RECEIVER SPECIFICATION (CONTD)

3.5.4 Drop Test

- (i) The receiver must not be damaged and must operate to specifications after being dropped onto a concrete floor from the height of one metre.

- (ii) The receiver must only suffer minor surface damage when dropped onto a concrete floor from a height of two metres. It must still function satisfactorily after this test.

3.5.5 Additional Requirements

See Section 7.

4. SYSTEM OPERATION

See FM 2a for background information.

5. BATTERY CHARGER SPECIFICATION

5.1 Battery Charger Unit

- 5.1.1 A combined battery charger unit must be available for both the transmitter and receiver units.

- 5.1.2 The battery charger unit must be capable of accepting both the complete transmitter and receiver.

- 5.1.3 The battery charger unit must also be capable of accepting an additional rechargeable transmitter and receiver battery pack which can both be charged concurrently with the main unit. It must also incorporate a mechanical interlock which would inhibit the charging of primary cells if they were accidentally placed in the charger. This is to protect against possible explosion of primary cells which may occur if recharging is attempted.

5.2 Charging Rate

5.2.1 Normal Charging Rate

At the normal charging rate the charger must be capable of charging complete units plus additional battery packs in six hours.

5. BATTERY CHARGER SPECIFICATION (CONTD)

5.2.2 Boost Charging

A boost charging rate must be incorporated for the additional battery packs. When "Boost" is selected cells should recover to 70% of normal capacity within one hour.

5.3 Overcharge Battery Protection

5.3.1 Normal Charging Rate Protection

At the normal charging rate the rechargeable cells must be protected against overcharging for at least 100 hours.

5.3.2 Boost Charging Rate Protection

At the boost charging rate the rechargeable cells must be protected against overcharging for at least 6 hours. It cannot be assumed that cells are fully discharged when placed in the charger unit.

5.4 Contacts

5.4.1 The electrical contacts should be constructed from a corrosion resistant material such as stainless steel (copper based alloys are highly susceptible to corrosion problems and are not preferred).

5.4.2 The contacts or sockets should be such that transmitter or receiver orientation in the charger does not affect the charging polarity if applicable.

5.5 Multiple Charging Unit

A unit is also required for charging 8 to 10 transmitters and a similar number of receivers and associated rechargeable cells. This could be constructed in modular form from single charging units.

6. ACCESSORIES

6.1 Cords

6.1.1 V-Cord A

A parallel "V" cord for connecting the receiver to two post auricular hearing aids must be available and it must be compatible with receiver and NAL hearing aids.

6.1.2 V-Cord B

A parallel "V" cord for connecting the receiver to two body aids must be available and compatible with receiver and NAL hearing aids.

6.1.3 Single Cord A

A compatible cord for connecting the receiver to a single post auricular hearing aid must be available.

6.1.4 Single Cord B

A compatible cord for connecting the receiver to a single body aid must be available.

6.2 Additional Battery Packs and Holders

Additional battery packs and holders must be available when required for replacement purposes.

7. ADDITIONAL REQUIREMENTS

7.1 Case Parts

The case and accessories of all units covered in this specification must be constructed from a durable scratch resistant material and be of a professional standard (professional standard implies good surface finish, accurate colour matching and mating of parts).

7.2 Case Colours

7.2.1 The colours of the various items must be negotiated with the National Acoustic Laboratories.

7. ADDITIONAL REQUIREMENTS (CONTD)

7.2.2 The colours selected must be maintained over the full contract period, to maintain interchangeability of parts.

7.3 Controls

All controls should be easily accessible, rugged and smooth functioning.

7.4 Temperature

All items must maintain specifications when operated for prolonged periods at ambient temperature from 0 to 45 degrees celsius and relative humidity up to 95%. All items must operate with reduced performance in ambient temperatures from -10 to +60 degrees celsius.

7.5 Maintenance

Ease of servicing must be a major consideration in the design of all items.

7.6 Identification

Each aid must have a clearly marked identification number or serial number. Manufacturers name or any advertising matter must not appear on any part of the system unless approved by the Director of N.A.L.

7.7 Technology

Thick film technology and packaging would be preferred over other packaging techniques.

7.8 Environmental Testing

- (i) In addition to above requirements, the components and equipment must comply with Australian Standard 1099 - "Basic Environmental Testing Procedures for Electronic and Telecommunications Purposes".
- (ii) In particular, the components and equipment must comply with the "Standard Climatic Sequence" Section 1: paragraph 1.6. Components must comply with category 10/70/21 as specified in Appendix A, part 1.

7. ADDITIONAL REQUIREMENTS (CONTD)

7.8 Environmental Testing (Contd)

- (iii) The specific clauses and test conditions of Australian Standard 1099 which apply are listed in a document entitled "Environmental Testing of Small Electronic Equipment", NAL, Latest Issue.

7.9 Drop Test of Coupled Transmitter-Receiver

- (i) The coupled transmitter-receiver must not be damaged and must operate to specifications after being dropped onto a concrete floor from a height of 0.7 metre.

- (ii) The coupled transmitter-receiver must only suffer minor surface damage when dropped onto a concrete floor from a height of 1 metre. It must still function satisfactorily after this test.

TRANSMITTER AUDIO PROCESSING CHIP
(INSIDE DOTTED LINE)

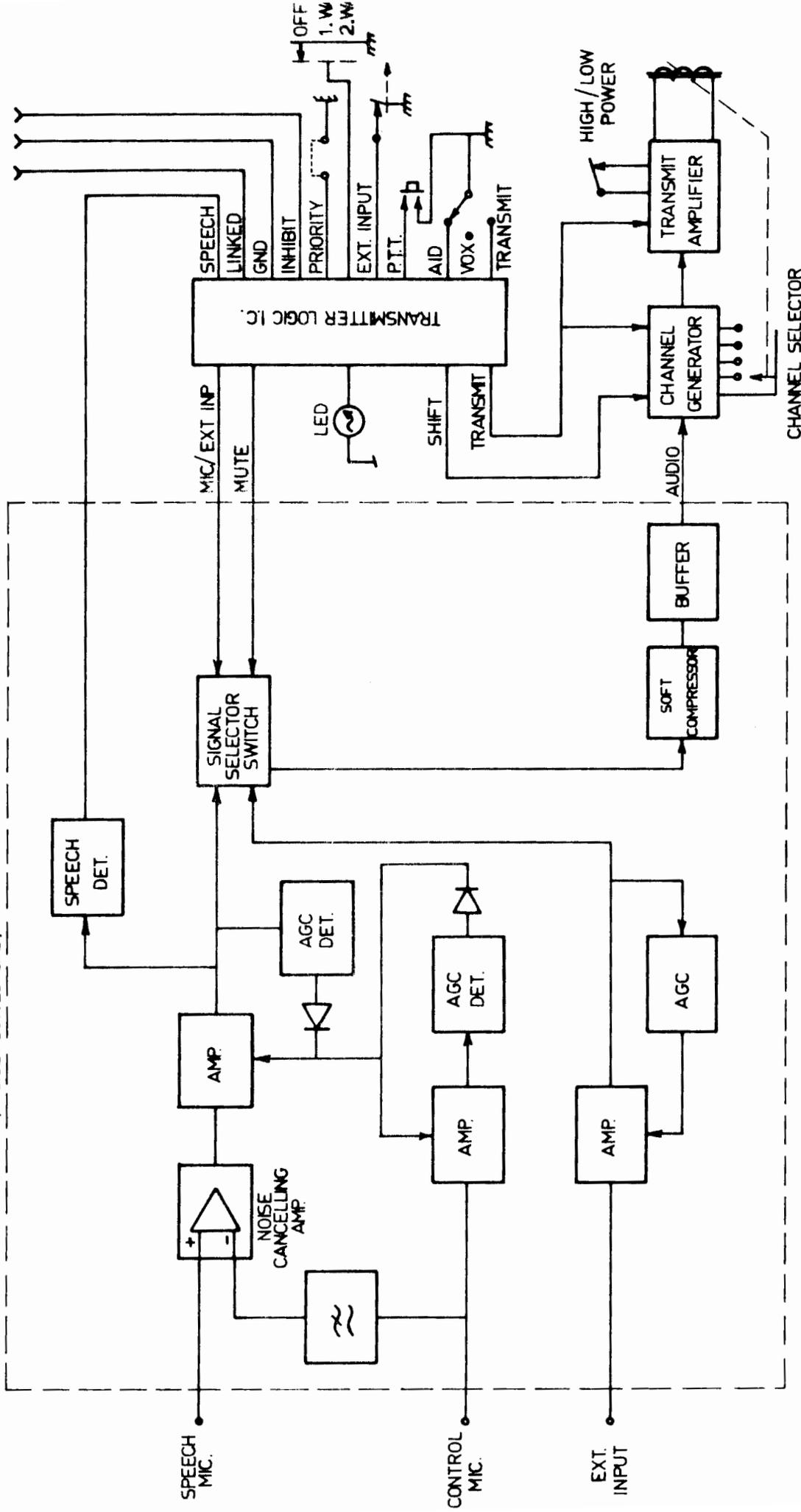

BLOCK SCHEMATIC TRANSMITTER FIG. 1

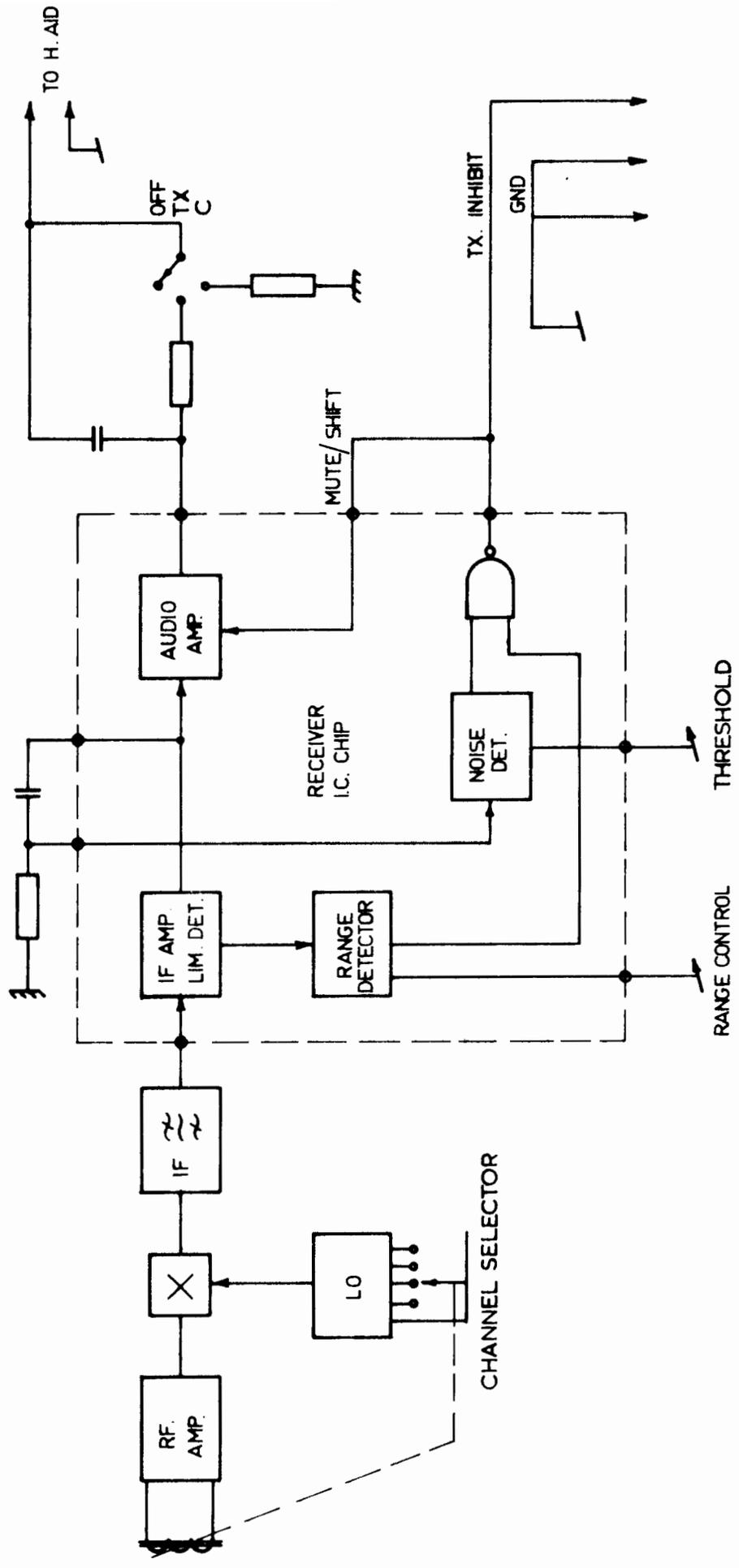

BLOCK SCHEMATIC RECEIVER FIG. 2

Total response for AGC threshold,
(Amplifier pre-emphasis 6 db/oct.,
with 3 db point at 2 kHz, and roll of
6 db/oct. below 100 Hz)

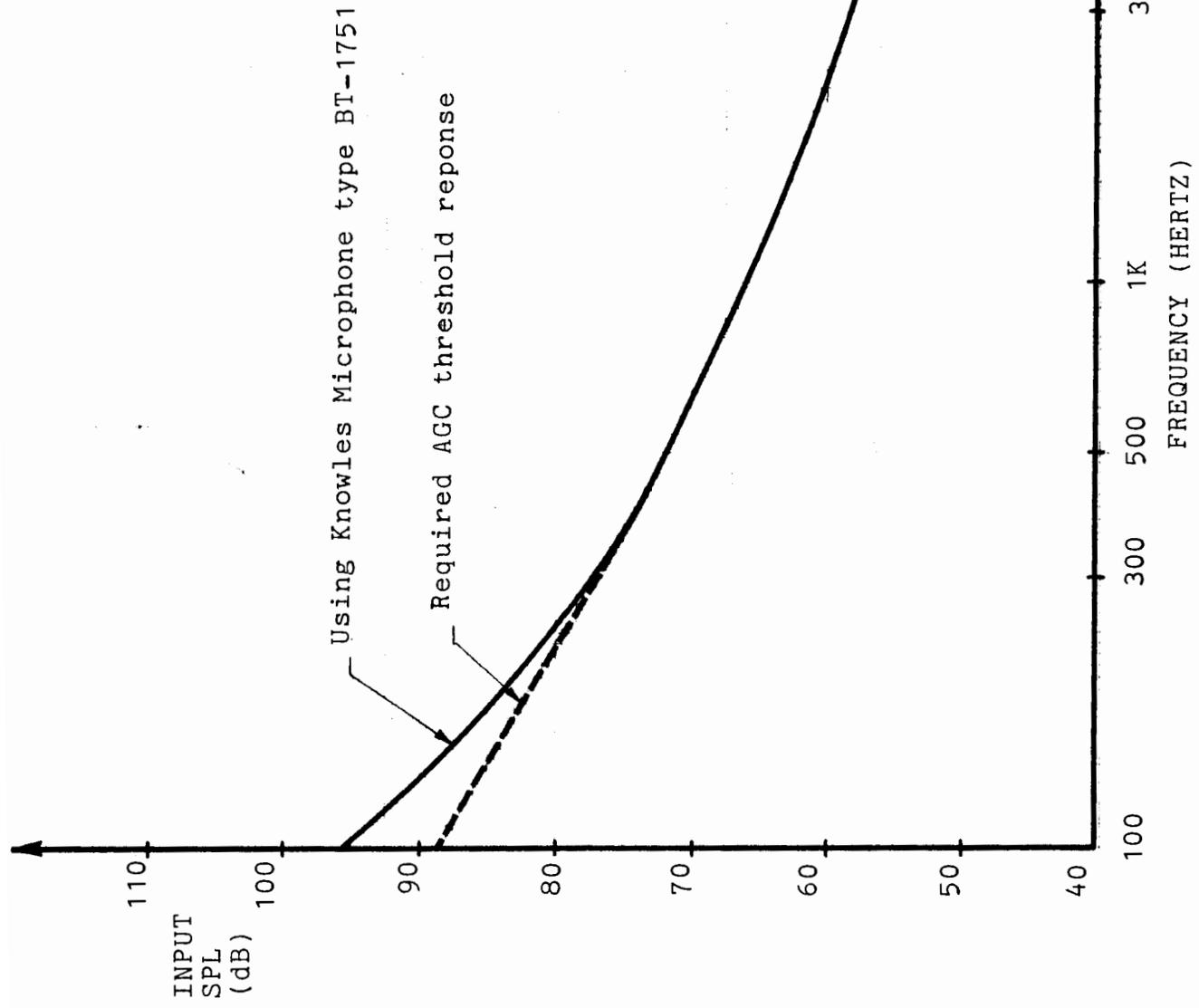

TRANSMITTER PRE-EMPHASIS - FIG. 3